

Solar UPS V2

Solar Uninterruptible Power Supply

DIN rail variant

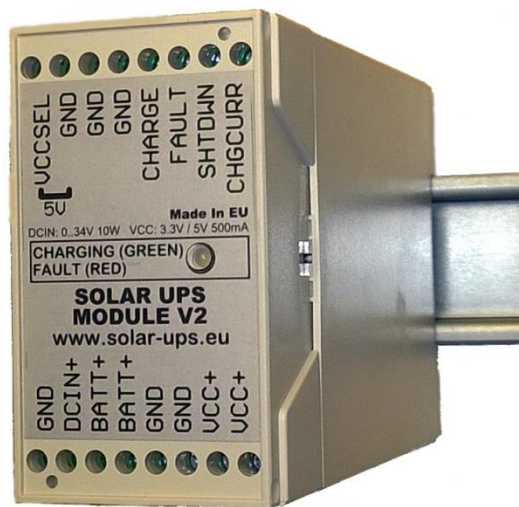

Installation Manual

<http://www.solar-ups.eu>

You can find there a downloadable datasheets and guides.

Warranty	Stamp
Date:	
Distributor:	
Serial Number:	

The warranty refers only to undamaged devices operated under the specified conditions of use!

HW: V2R2

2017. january 20.

Minimal wiring schematic

The 10W solar panel and **GND / VCC+** cables has to be wired in the minimum wiring diagram of the Solar UPS module. If there is a GSM/GPRS/3G/4G modem on the supplied device, then **BATT+** cable has to be wired there. This should be led also in the ADC unit of the application controlling processor with practical voltage distribution, so that the processor would detect low battery status and could switch off the modem if required (BATT+ wire ensure constant supply with the risk of battery's total discharge.).

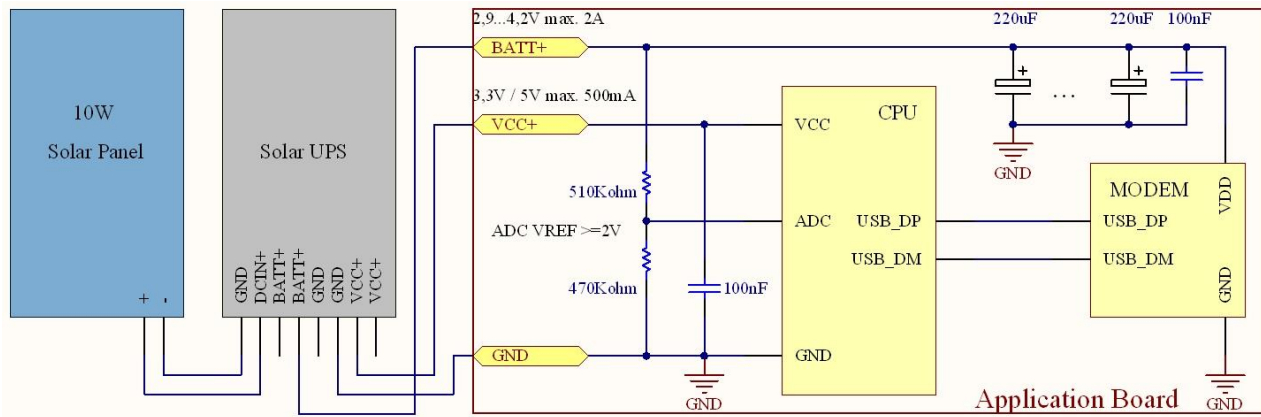

Charge Current Measurement

Solar UPS is capable of measuring the charging current of the batteries and forwarding it through a voltage output as an analogue signal. The voltage of the signal is proportional to the value of the charging current, with $1\text{mV} = 1\text{mA}$ change. The maximum charging current is 2A, so the maximum voltage at the **CHGCURR** output is 2V. Measuring of the signal is possible in the below two ways. In the first case the reference voltage of ADC used for the measurement is above 2V, in the second case it is between 1V and 2V. It is practical to give also ESD protection for the input.).

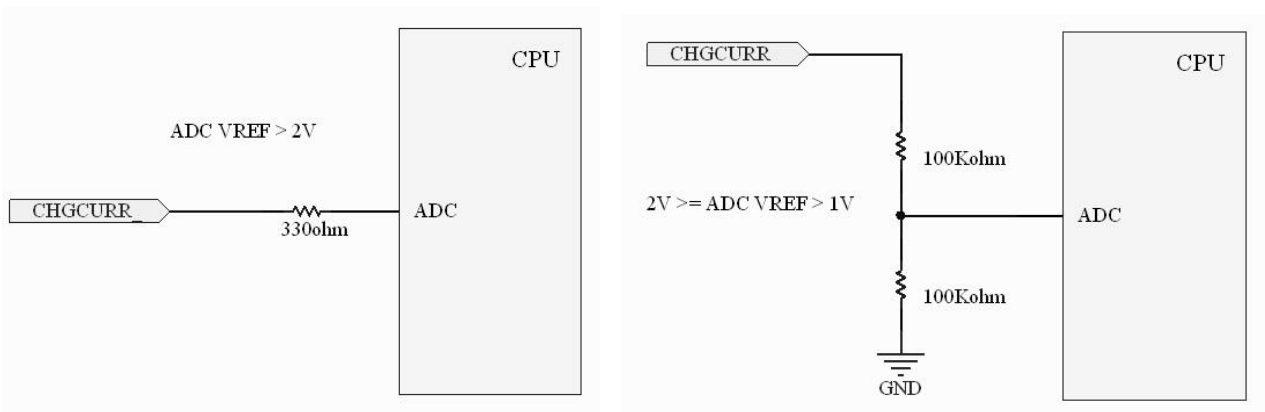

State outputs

Two charging status signals are led through the Solar UPS; the signals of **CHARGE** and **FAULT**. Their conditions are indicated by the LED on the module with green or red colour. Indication of the conditions can be solved with a LED in the same way (first figure), as well as, their connection to the processor on the fed circuit. (second figure). Possible conditions:

	STBY or SHTDWN	BATTERY FAULT	CHARGING	TEMP FAULT
CHARGE	HIGH-Z	HIGH-Z	LOW	LOW
FAULT	HIGH-Z	LOW	HIGH-Z	LOW

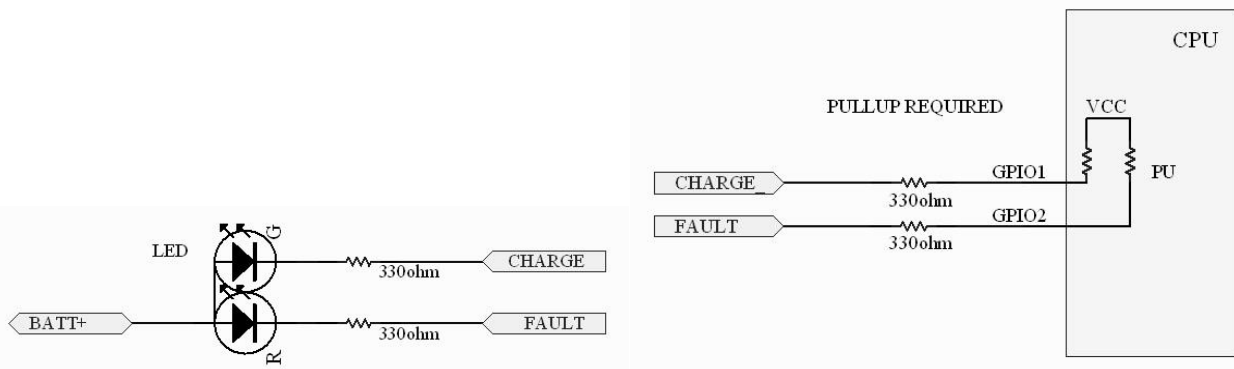

Shutdown input

The operation of the charging current can be disabled in the Solar UPS module with the control signal **SHTDWN**. When this input is pulled in the low condition then charging of the battery will be disabled. Controlling must be solved with an OC transistor circuit (below figure) because the value of the internal resistance in the SHTDWN port must not be modified, when not in the pulled low condition (any other solution may result in faulty operation). In case disabled state must be produced on the device due to maintenance/service, then it can be manually done, by connecting the SHTDWN and the GND port.

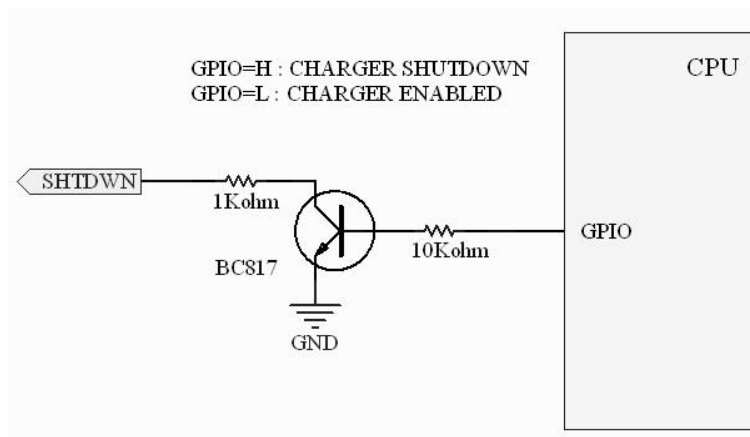

Select VCC and set temperature protection

Voltage of VCC+ output may be 3.3V or 5V, depending on the setting of the **VCCSEL** port. When this port is disconnected then the default voltage of the VCC+ output is 3.3V. When the VCCSEL port is closed to the GND port (first figure), then the voltage will be 5V at the VCC+ output.

Temperature protection of the charger can be optionally activated. This can be done with the internal **JP2** jumper. In its closed position the charging current will charge the battery only in the ambient temperature range of 0...45 degrees. In open condition the protection is inactive; the temperature would not affect charging (default). The jumper is accessible after snapping off of the faceplate from the device (the faceplate can be snapped off with a small flat screwdriver at the two sides; mind the position of the LED when replacing).

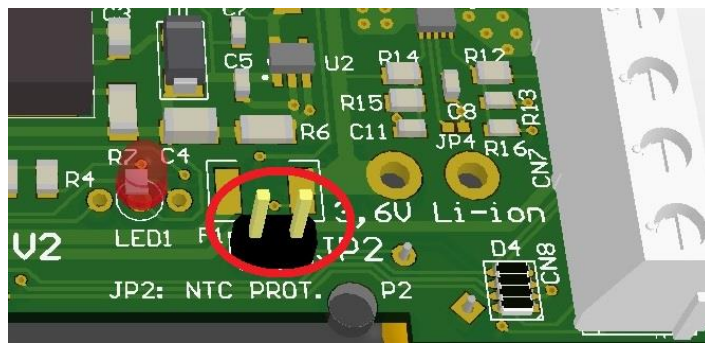
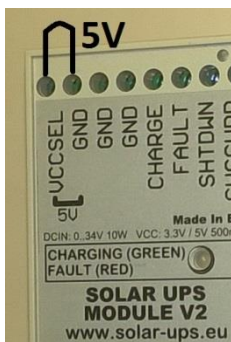

Getting started, first steps

Parameters of the solar cell: Power 5-20W (10 W is the optimum), 16-24V of voltage to maximum performance, max. 34V of idle voltage. When connecting the solar cell, special attention should be paid to the fact, that the panel is continuously under voltage in sunshine. Care must be taken that the cable coming from the solar cell should only be wired to the DCIN+ and GND ports!

The charger is tuned in default to panels belonging to the maximum performance of **17.0...17.5V**. In case the parameter of the connected solar panel differs from this, then POT1 must be set. The way of setting: With the help of a laboratory supply unit - voltage equal to that belonging to the maximum performance of the panel shall be given to the DCIN+ and GND ports. Then **POT1** should be set so that voltage on the **JP1** measuring point be **2.75 V** (below figures). POT1 is accessible after snapping off of the faceplate (previously discussed).

